



**INNOVATING
POSSIBILITIES**

Kartikeya Industries Private Limited



At the forefront of engineering solutions, Kartikeya Industries Pvt. Ltd. is all about increasing customer satisfaction without increasing costs while leveraging quality, efficiency and innovation.

.....

VISION

Kartikeya follows a unique philosophy of granting individuals the authority to set their own targets and the freedom to achieve their goals. This simple vision has created an environment where there is no limit to aspire, no limit to transform and thus proved to be a powerful engine of growth for the enterprise.

MISSION

Kartikeya is committed in providing complete solutions to our esteemed customers through a proactive and responsive approach by meeting quality, service, right price through innovation, efficient management and adopting latest technologies. The company is also committed to continually provide training, growth opportunities to its employees and to interact with integrity, honesty with the community, business associates and stake holders while maintaining sustainable growth.



DELIVERING
CUSTOMER
SERVICE WHILE
LEVERAGING
QUALITY

At the forefront of engineering solutions, Kartikeya Industries Pvt. Ltd. is all about increasing customer satisfaction without increasing costs while leveraging quality, efficiency and innovation. Looking ahead, we are focused on reaching new horizons consolidating our operations to provide turnkey solutions and provide end to end solutions to our esteemed customers.

Expecting better economic growth will emerge in the coming times and by virtue of our ability to perform, we are exploring new avenues for growth and stability of our organization.

The landmark year 2013 witnessed the arrival of a new star on India's rapidly growing industrial horizon. A futuristic engineering company was envisioned by seasoned technocrats with decades of expertise in Cold Forming, Light Engineering Fabrication and Trading. With factory anchored in a sprawling space of 13 acres at Mominpet near Sadashivpet, Hyderabad in Telengana, the engineering enterprise was strengthened with state of the art infrastructure for the manufacture of intricate profiles for a variety of applications and it never looked back ever again.

Today, while the products manufactured by the company are in conformity with Indian and International Standards, it has engineering and design capabilities to scale new frontiers of technical excellence coupled with committed high degree of service and quality. Backed by in-house capacity to deliver 30,000 MT per annum of Cold Forming Sections and Light Engineering Fabricated Structures, the rapidly progressing entity has forayed into manufacturing parts of railway coaches.



Achievements and milestones

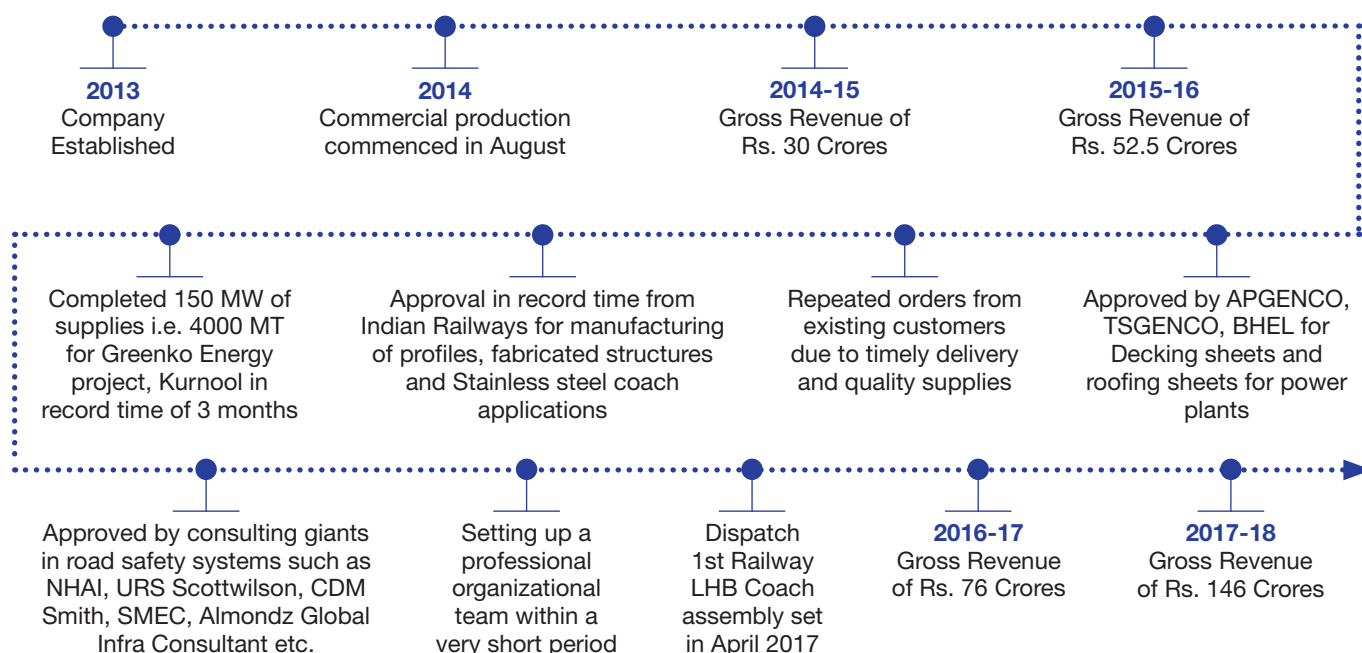

PRODUCTS & SERVICES

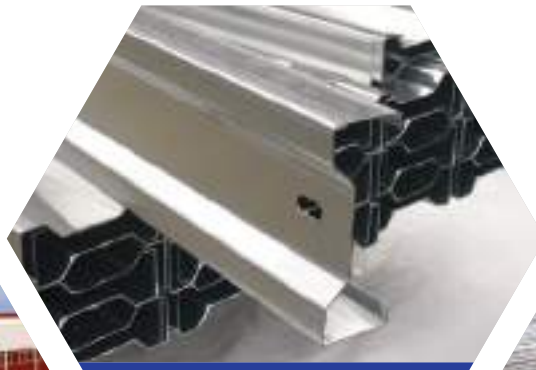

Purlins



Pre-Engineered Buildings (PEBs)



Decking Sheets



Railway Coaches



Metal Crash Barriers
/Guard rails



Roofing Sheets &
Accessories



Solar Module
Mounting Structures

FACTORY

Kartikeya Industries Private Limited is a versatile engineering industry established in 2013 near Sadasivpet (Hyderabad), Telangana. We are first generation entrepreneurs with vast experience of over 40 years in the field of Cold Forming, Heavy Engineering Fabrication, Pre – Engineered Buildings, Cold Forming and manufacturing Railway coach components and acquired expertise in running large professional organisations. We are also proud to inform you that our company is headed by experienced technocrats and engineers to deliver quality products with committed deliveries and at right price.

With factory anchored in a sprawling space of 15 acres at Mominpet, near Sadashivpet, Hyderabad in India's youngest state of Telangana, the unique engineering enterprise is strengthened with state of the art infrastructure for the manufacture of intricate profiles for a variety of applications.

- C & Z Purlin Machines
- CNC Plasma Cutting Machine
- Robotic Spot Welding Machine
- CNC Laser Cutting & Welding Machine
- CNC Press Brake
- SAW Welding Machines
- Sheeting Machines
- Cutting Machines





Committed to adding value to the company's growing customers, it has the capacity to deliver around 36,000 MT of steel per year in an eco-friendly manner.



PRE-ENGINEERED BUILDINGS (PEB)

Kartikeya is heralding a change in the pre-engineered steel building industry in India through innovative engineering solutions and software technologies. The company's core team has expertise in innovating customised, economical designs and uses specialised software packages and cutting-edge computer hardware. What distinguishes Kartikeya's approach is the immaculate manner in which its consultants analyse all kinds of PEB Structures ranging from low to high complexities. Additionally, what exceeds expectations is their ability to correct oversights at the drawing board itself in order to do away with extraneous expenditure.

Kartikeya Industries Pvt. Ltd. offers its customers with unmatched solutions in Pre-Engineered Buildings (PEBs). Owing to numerous benefits such as



Reduced Construction Time



Low Maintenance



A worldwide Reputation for Durability



Water Resistance



Earthquake Resistance



Simplifying Expanding Operations

Super PS Building, CP Aqua, Rajahmundry



Kartikeya Industries Pvt. Ltd, Unit II





NCC Crowns Ltd,Hyderabad



ARJAY Enterprises,Hyderabad



Hindustan Coca Cola, Khurda, Odisha



PURLINS

With Cold Formed Steel used as the basic material of construction - as Hot Rolled Steel (ISMC Sections) is a thing of the past - and considering the higher strength to weight ratio of CRF Sections, Kartikeya's Purlins have gained wider acceptability in a myriad of construction activities. It includes construction of steel buildings, industrial warehouse, a PEB, or even a complex Turbo Generator building in a power plant. What's more, Cold Formed Purlins are well accepted by architects, structural consultants all over India and rest of the world.



We Supply Purlins in exact cut to length, punched condition as per the requirement for easy erection and to avoid re-work/wastage at site. Z-Purlins, C-Channels, Lip Channels, Multi-Beams, Angles and many more profiles are available in a range of 1.2 mm to 6 mm. Sections can be supplied in various grades of steel to meet your exact requirements. Manufactured from quality raw materials with HR and Galvanized Steel as most commonly used material, Kartikeya allows room for flexible design options.

Technical Specifications

Thickness	1.2 mm to 6 mm
Length	Up to 12 meters
Material	HR Steel, CR Steel, Galvanized Steel (120GSM/275GSM)
Yield Strength	245 MPa/345 MPa
Surface Condition	Bare, Primer Coated, Galvanized, Epoxy Primer Coated



C-Channels

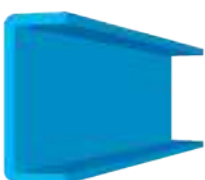

Lip - Channels



Multi - Beam



Z-Purlin (45 Lip)



Z-Purlin (90 Lip)



ROOFING SHEETS

When it comes to long lasting materials and immaculate quality, Kartikeya Industries Pvt. Limited offers best roof sheeting solutions in this part of the world. Made from high quality materials and available in Bare Galvalume/ Colour Coated Galvalume/ Colour Coated Galvanized Steel with thickness ranging from 0.47 mm to 1.0 mm, they are designed to render an aesthetically attractive disposition.

Assuring a new level of performance and enduring excellence, the profiles are supplied in exact cut-to-length up to 12 meters, as per customer's requirement. After all, each of the company's products are a result of the team's many years of research and development. What's more, Kartikeya's roof sheeting solutions come in a wide range of colours that blend harmoniously with your structure's present colour scheme.



Base Material	CR Steel (IS 513, AS 1397)
Yield Strength	240 MPa, 340 MPa & 550 MPa
Galvalume Coating (PPGL)	AZ 150 (Al-55%, Zn-43.4%, Si-1.6%)
Zinc Coating(PPGI)	120 GSM, 275 GSM
Paint Coating	Regular Modified Polyester(RMP), Silicon Modified Polyester(SMP), Poly Vinyl Di Flouride (PVDF/PVF2)
Painting thickness(Top)	18-20 microns
Painting thickness(Bottom)	5-7 microns Alkyd back coat
Colours Availablet	Light Blue, Off White, Mist Green, Turquoise Blue, Bare Galvalume, Brick Red etc.

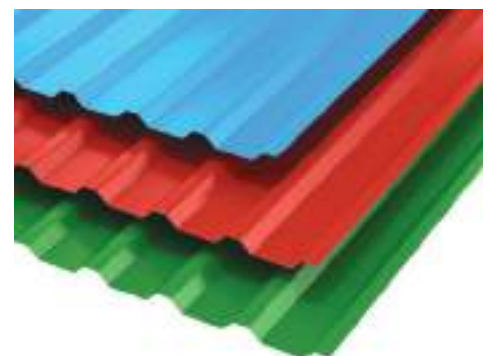

Roofing Accessories

An impressive range of Roofing Accessories compliment the roofing sheets that include: Ridge Capping, Valley Gutter, and other Flashings along with turbo ventilators, Louvers, poly carbonate sheets (Skylights), fasteners and more. A wide range of guttering, downpipe and steel fascia profiles are also available in styles to suit your requirement.



DECK SHEETS

TUFFDECK by Kartikeya Industries Pvt. Limited reinforces the cornerstones of robustness and reliability while providing a modern, clean line. A quality Composite Deck sheet, TUFFDECK is a steel profile with ribs, embossments which helps in binding with concrete slab and together forms a part of the floor structure. This interlocking between the concrete and the floor deck creates a reinforced concrete slab that serves the dual purpose of permanent shuttering and reinforcement.

IIT, Hyderabad



The rising standards of Indian Construction Industry and changing times have catapulted Composite decking as the most effective method of constructing floors in steel buildings. It has tremendous advantage in high rise buildings as well. What's more, by design, TUFFDECK Sheets foster cost efficiency and design flexibility while providing ease of use, enhanced safety, better intensity as well as less deflection.

Technical Specifications

Length	Upto 12000 mm
Material	CR Steel, HR Steel, Galvanized, Colour Coated
Yield Strength	245 MPa to 345 MPa
Type	Bare, Primer Coated, Galvanized, Pre-Painted

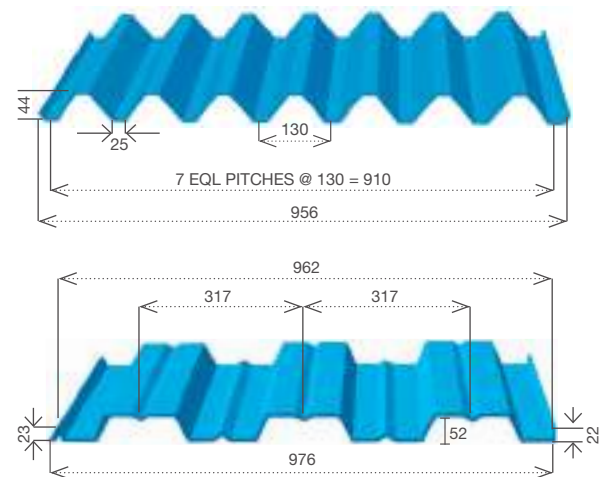

ROAD SAFETY SYSTEMS

A national focus on making roads safer is an essential element of Kartikeya Industries Pvt. Ltd. So with a view to transform India into a largely connected and highly secure country, Kartikeya manufactures and supplies a wide range of Guardrails that are strong, sturdy and aesthetic. The products conform to national and international standards such as MORTH, AASHTO M180 and EN 1317-1 and 2. What's more, the quality-oriented company offers end-to-end solutions that embrace manufacturing as well as installation.

Aimed at offering a safer operating environment for all road users, the metal crash barriers play a pivotal part in protecting vehicles and passengers, in case of an accident, and also serve a beneficial visual representation to the drivers, especially after dark. Towards this end, Kartikeya is proud to be associated with renowned infrastructure companies including IJM Infrastructure, Era Infra, KNR Constructions, HKR Roadways, RN Constructions, Sudharma Infra, Hyderabad/Cyberabad Expressways and many more.

Hyderabad Outer Ring Road



Rajahmundry to Kovvur Road



Palakkad, Kerala National Highway



Types Of Barriers

Metal crash barriers conforming to all major specifications like:

- Ministry of Road Transport & Highways, India (MORTH)
- American (AASHTO M180)
- Euronorm (EN 1317 – 1 & 2)



Single Faced Single Barrier



Single Faced Double Barrier



Double Faced Single Barrier



Double Faced Double Barrier

RAILWAY COMPONENTS

Kartikeya Industries Pvt. Limited offers specialised solutions that are specifically crafted to meet the growing needs of railways. From manufacturing parts of Railway Coaches to developing unique requirements for rail coaches, Kartikeya is a one stop solution for continued growth and success.



Unmatched quality and productivity at full speed

The railway solutions are delivered under the watchful eyes of Kartikeya's visionary leadership with decades of expertise in engineering to provide the reassurance of unmatched quality you can trust, and efficient core team members who are able to provide productivity at full speed.

Kartikeya can cost-effectively produce the following products for coaches:





Various cold roll formed profiles used in rail coaches

MRVC Cantrail (ICF)

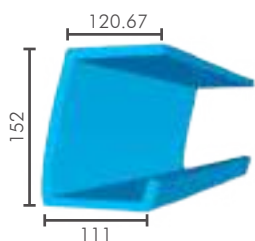

Regular Cantrail (ICF)

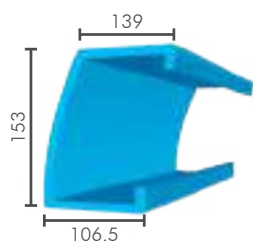

MRVC Cantrail (ICF)

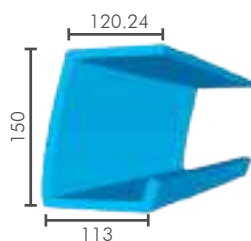

MRVC Longitudinal Beam (ICF)

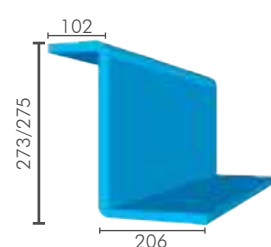

Side Sill - DMRC (BEML)

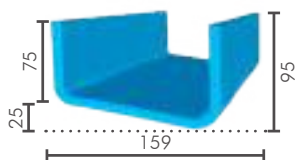

Cantrail - DMRC (BEML)

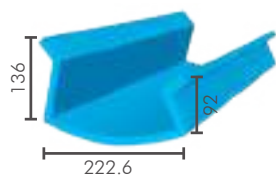

Light Rail (ICF)

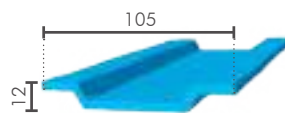

Waist Rail (ICF)



Roof Panel - DMRC (BEML)

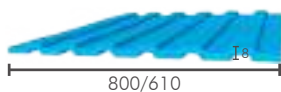

Roof Panel for LHB

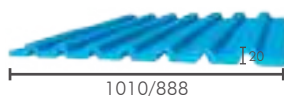

Key Stone Plate - DMRC (BEML)

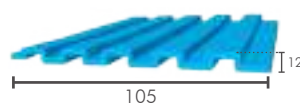

Sole Bar (ICF)

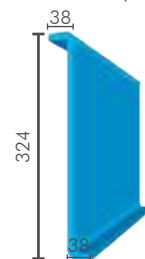

Trough Floor Regular

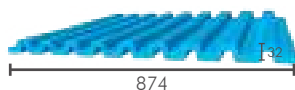

MRVC Trough Floor

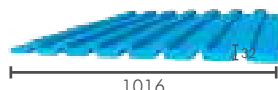

U Stiffner (ICF)

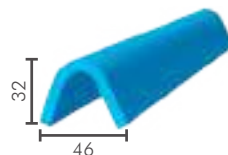

SOLAR MODULE MOUNTING SOLUTIONS

Apart from standing out as a futuristic engineering company with years of experience in Cold Forming, Light Engineering Fabrication and Trading, Kartikeya Industries Pvt. Ltd. is equally adept in manufacturing a vast assortment of Solar Module Mounting Structures. Lightweight yet strong, Kartikeya uses proven and reliable materials to ensure that the company's solutions weather the testing climatic conditions for years to come.

Thandon Infra, Madhurai



Greenko Energy, Kurnool



Avi Solar, Eluru





A range of solar segments at short mounting times Based on the designs enabled by the customer, the competent team at Kartikeya that specialises in Solar Module Mounting Structures can provide a range of solar segments at short mounting times. What's more, a bouquet of other benefits such as cost efficiency, immaculate quality and maximum durability enhance the experience of turning to Kartikeya for your custom requirements. After all, Kartikeya's aims is to surpass its customers expectations, always.

Kartikeya can cater to the following Solar Power Segments

..... Ground Mounted Solar Projects Roof Top Solar Projects	
				
Fixed Angle/Rigid	Seasonal Tilt	Tracker Type	Residential/Flat Roof	Industrial/Slanting Roof

Technical Specifications

Thickness	1.2 mm to 6 mm
Length	Up to 12000 mm
Material	CR Steel, HR Steel, Galvanized Steel
Yield Strength	245 MPa, 345 MPa & 550 MPa
Type	Bare galvalume, Pre-galvanized and Hot dip galvanized
Zinc Coating	120 GSM, 275 GSM, 350 GSM, 550 GSM for Pre Galvanized Steel, Bare Galvalume (Zn - Al Alloy Coated Steel), 60 microns - 120 microns for Hot Dip Galvanized Steel (Based on thickness)

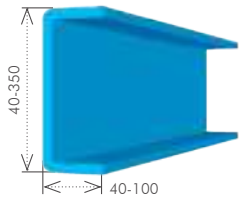
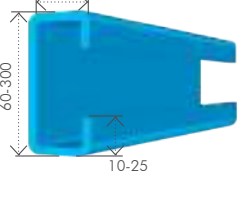
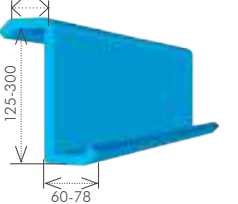
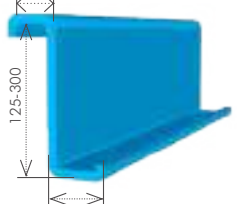
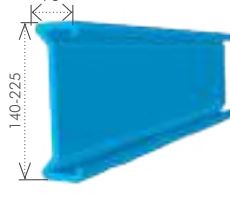
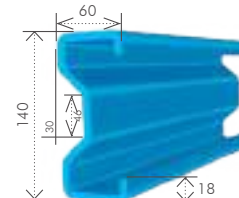
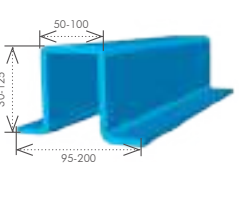
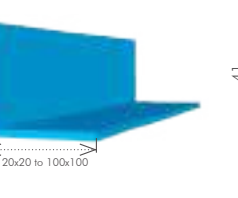
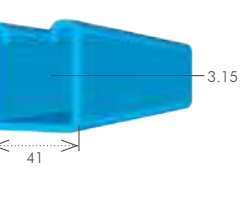
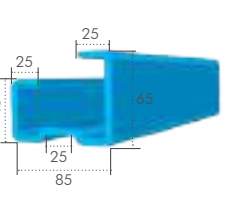

Profiles

<p>C-Channels</p> 	<p>Lip - Channels</p> 	<p>Z-Purlin (45 Lip)</p> 	<p>Z-Purlin (90 Lip)</p> 	<p>Multi - Beam</p> 
<p>Sigma Section</p> 	<p>Top Hat</p> 	<p>Equal Angle (90)</p> 	<p>Strut Channel</p> 	<p>Uneven Sigma</p> 

CLIENTS





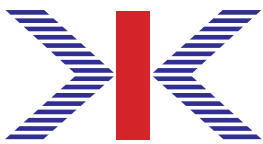

Aspire to Excel

Kartikeya Industries Private Limited

464/16-3-V, Vasanth Nagar,
Kukatpally, Hyderabad - 500072,
Telangana, India.

Phone: +91 40 40208040

Mobile: +91 76600 01105, 76600 01110

E-mail: marketing@kartikeyaindus.com

www.kartikeyaindus.com